

## SMART GARBAGE BIN

<sup>1</sup>C. Poongodi, <sup>2</sup>M.Kowsalya, <sup>2</sup>S.NaveenKumar, <sup>2</sup>H.Kavibharathi  
<sup>1</sup>Assistant Professor, <sup>2</sup>UG Scholar,

Department of IT, Kongu Engineering College, Erode, India  
poongs@kongu.ac.in, naveensakthivel13@gmail.com

***ABSTRACT-Nowadays, in our city we see that the garbage bins placed in public places are overloaded due to the increasing wastes. In many places the dustbins are not cleaned in proper time. It creates the unhygienic problems,land pollution and also create the uneasiness to the surroundings and it spreads some harmful diseases to the people. To avoid all such situations we are going to develop a project titled“SMART GARBAGE BIN”. In this proposed system, there are multiple dustbins located in public places.Here our main motive is to inform the administrator or any other authority who is responsible for the environment lookup of an organization. This project helps him in finding whether the garbage bin is empty or filled and if it is filled, it also has the feature to inform the concern department to clean it immediately. It also specifies the location of the garbage bin. So it is very easy to know which bin is filled or empty. Here we have 2 sensors. One for looking up the level of the garbage and other for measuring the weight of the garbage bin. Initially a threshold value is set and when the sensors reaches the threshold value, a message is sent to the authority that the garbage bin is filled or emptied at a particular location. Here the main thing is that both the sensors should meet the threshold value, then the message is sent to the respective authority. Here the information which is obtained from the sensors must be transmitted to the “mobile application” through the wireless communication medium. Then through the “mobile application” we can send a message to the concerned representative***

***about the garbage bin and also inform them to replace it.***

***The collected data is then used for monitoring and optimizing the daily selection of trash cans to be collected,calculating the routes accordingly.After the trashcans to be collected have been selected, route optimizationalgorithms calculate the best route to follow.***

***Keywords: Node MCU ESP8266, Bluetooth hm 10 module, Ultrasonic sensor hcsr04***

### 1. INTRODUCTION

With the increase in population, change in living lifestyle and increased number of industries, the amount of Municipal Solid Waste (MSW) is increasing at a very high pace. Solid waste management is a big challenge in urban areas for most of the countries throughout the world. An efficient waste management is a pre requisition for maintain a safe and green environment as there are increasing all kinds of waste disposal. There are many technologies are used for waste collection as well as for well managed recycling. The Information gathering is big and cumbersome. The concurrent effects of a fast national growth rate, of a large and dense residential area and a pressing demand for urban environmental protection create a challenging framework for waste management. The complexity of context and procedures is indeed a primary concern of local municipal authorities due to problems related to the collection, transportation and processing of residential solid waste today

the garbage collection is manual which takes a lot of efforts and is time consuming. In this project, we are using sensors to detect garbage level in garbage bin. As soon as the garbage bin is full / overflowing then that information is sent to the concerned authority. Also we have used Load cell based weight sensor which will sense the weight of the garbage bin and when the weight crosses the threshold value, the information is sent to the concerned authority. After the message is sent the workers are informed to clear the garbage bin.

## 2. EXISTING SYSTEM

In the existing system consists of manual process i.e., people on the trucks will go and check whether the bin is empty or not. Because of that, it is time consuming and less effective process. To overcome the above said problem GSM facility had been introduced to find the location and to clean the dustbins.

### 2.1 DISADVANTAGES

- The system is totally manual.
- It requires more human resource to run the system.
- High costs
- Unhygienic Environment and look of the city
- It spreads bad smell and may cause illness to human beings

## 3. PROPOSED SYSTEM

The proposed system focuses on the waste collection process. It reduces the time consumption and it is an automated process. The status of the bin is continuously monitored and sends the notification to the specified authority via the android application.

### 3.1 ADVANTAGES

- Improves Environment quality.

- Real time information of the dustbins.
- Cost Reduction and resource optimization.
- Effective usage of the dustbins.
- Intelligent management of the service.

## 4. BLOCK DIAGRAM

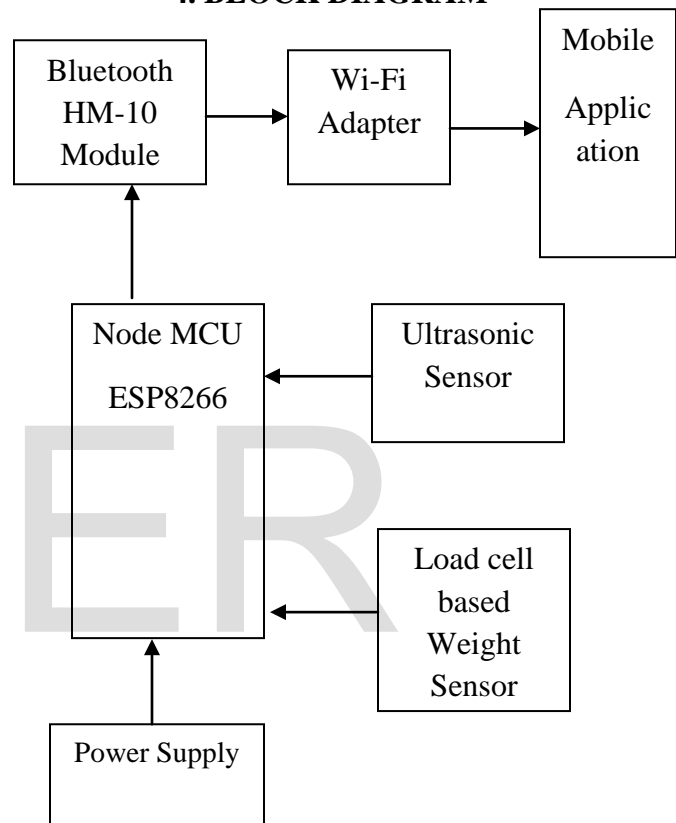

## 5. FLOWCHART

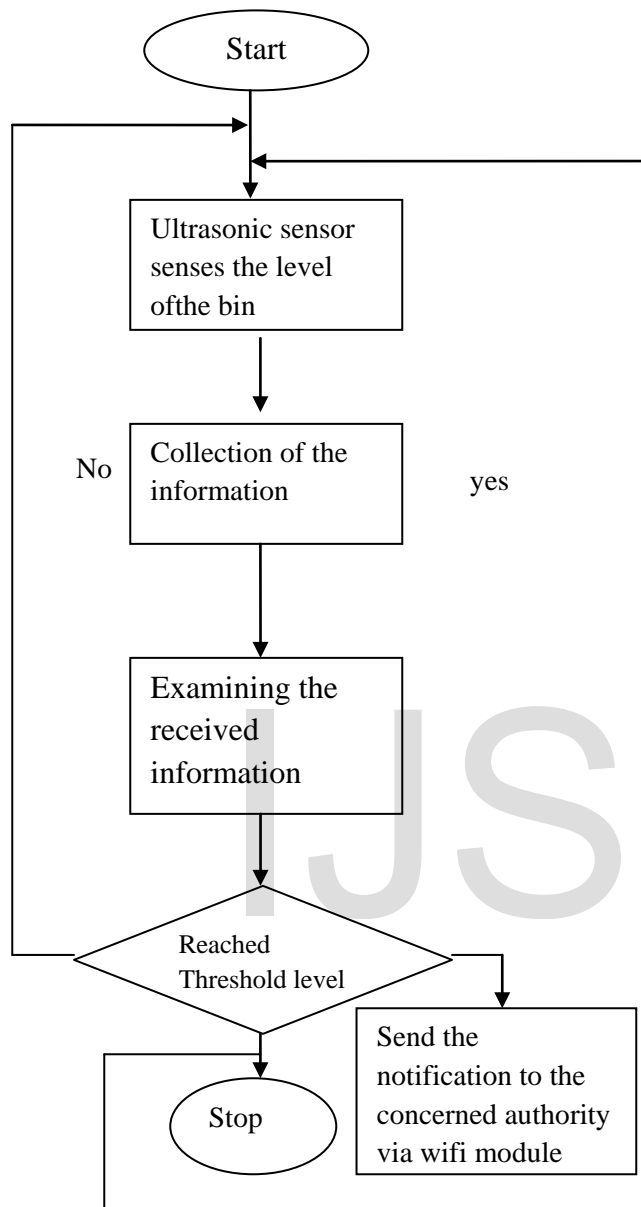

## 6. CONCLUSION

At present waste management is a major concern for the authorities responsible for this task. Waste collection is a costly service that consumes most of the municipality budget. It also creates a huge environmental impact. This paper introduces a real-time bin monitoring system framework by using various sensing and communication technologies integrated with

Mobile application. The experimental results show that the developed system responded as soon as the bin is filled and transmits the updated bin status to the concerned authority via wireless network. The authority can use the real-time bin information to show their status as well as can feed the data to an optimization model for route optimization. By implementing this project, it will avoid overflowing of garbage from the container in residential areas which is previously either loaded manually or with the help of loaders in traditional trucks.

## REFERENCES

- [1] Byung-In K., Seongbae K., Surya S., Waste collection vehicle routing problem with time windows, *Computers & Operations Research*, Volume 33, Issue 12, December 2006, Pages 3624-3642, ISSN 0305-0548
- [2] Kostakos V., Ojala T., and Juntunen T., Traffic in the smart city: Exploring citywide sensing for traffic control center augmentation, *Internet Computing, IEEE*, vol. 17, pp. 22–29, Nov 2013
- [3] Nuortio T., Kytöjoki J, Niska H., Bräysy O., Improved route planning and scheduling of waste collection and transport, *Expert Systems with Applications*, Volume 30, Issue 2, February 2006, Pages 223-232, ISSN 0957-4174
- [4] Piro G., Cianci I., Grieco L., Boggia G., and Camarda P., Information centric services in smart cities, *Journal of Systems and Software*, vol.88, no. 0, pp. 169 – 188, 2014